

A.C. COMPRESSOR MOUNT 40-134R

Small Block Chevy - Long Waterpump
Passenger Side

The compressor belt will run in the outer grooves of the crankshaft and waterpump pulleys originally used for the factory alternator. This bracket was designed to be used with our driver side alternator mount.

OLD AIR PRODUCTS www.oldairstproducts.com
DIVISION OF COLD AIR PRODUCTS INC.

1201 Forum Way South - Fort Worth, TX 76140
(817) 531-2665 - FAX (817) 531-3257

We use a belt length of 60" to 61" with this mount on installations in our shop. However this can vary with the diameter of your pulleys.

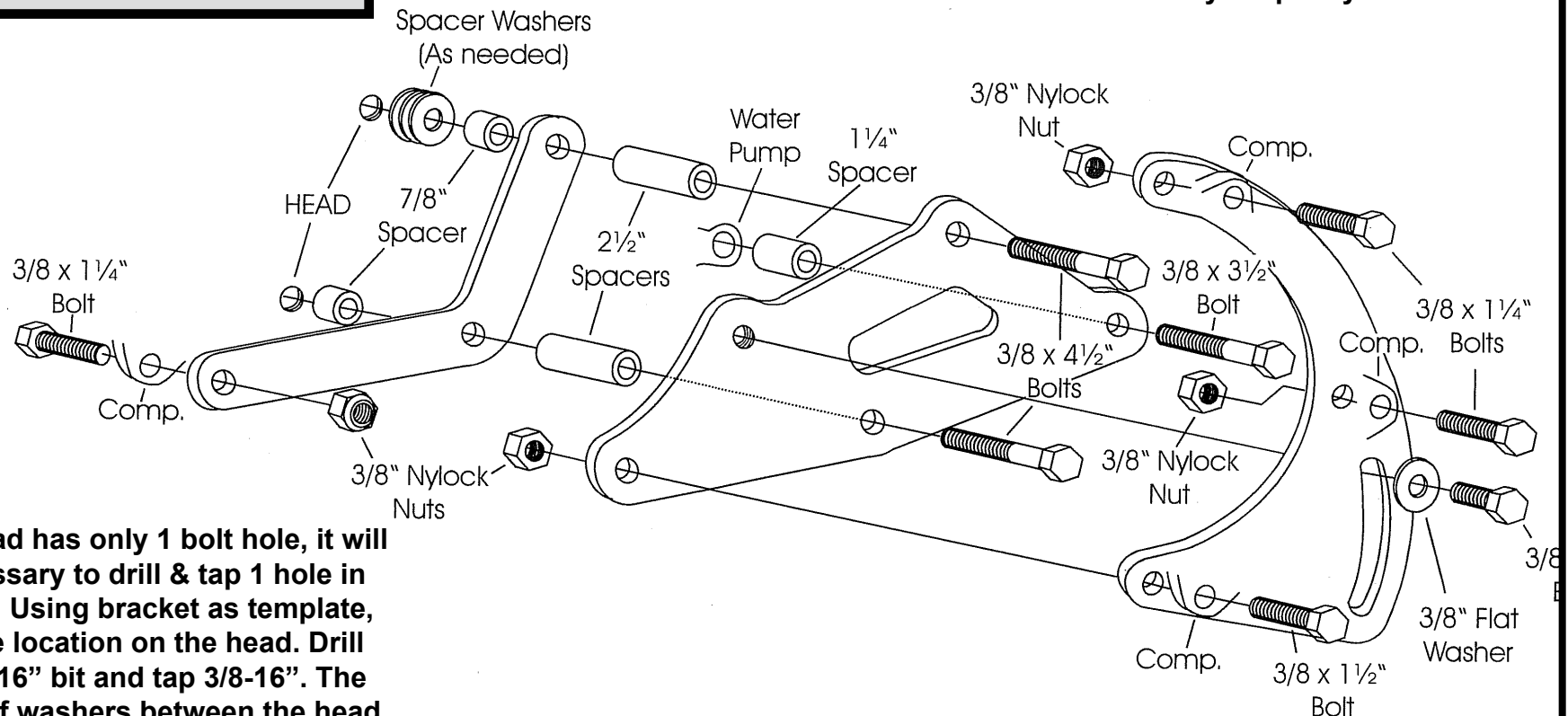

If your head has only 1 bolt hole, it will be necessary to drill & tap 1 hole in the head. Using bracket as template, mark the location on the head. Drill with a 5/16" bit and tap 3/8-16". The number of washers between the head and 1/4" spacer will vary with different castings. As with any mount system, assemble all of the brackets to engine **BEFORE TIGHTENING THE BOLTS**

As with any part of this nature, make sure it fits your application before painting or plating, Parts that have been painted, plated or modified may not be returned.